

# Sensitivity Analysis of the Environmental Impact of Chemical Processes Through Integrated Computer-Aided Modeling

F. Nourai\*, D. Rashtchian<sup>1</sup> and J. Shayegan<sup>1</sup>

A comprehensive representation of the environmental impact of a plant should incorporate not only the process variables that mainly affect the generation step but also the non-process ambient conditions that have influence on the dispersion step. Albeit, at best, only the process-related variables can be manipulated in order to optimize the environmental behavior of the process. In this study, an environmental model is coupled with a chemical process model. The approach is applied to an existing nitric acid production plant to study the effects of selected process variables on the environmental impact of the process. The insights that this approach provides can be used in retrofit studies to define the ultimate potential of the process in terms of source reduction as well as the appropriate direction of any modifications. The computer-aided integration of the two models improves the accuracy of the sensitivity analysis. It also makes the results much more realistic which is the key point in implementation of the proposed modifications. The environmental fate of the pollutants, i.e., nitric oxides, is programmed as a dispersion model. The model is linked to a process simulator that contains the process model. Sensitivity analysis of the environmental impact of the process has successfully revealed the most significant parameters that can affect the overall environmental performance of the plant.

## INTRODUCTION

Public awareness and opinion about the ever-increasing effects of industrial activities on the environment and economic impact of this issue are some of the reasons that have forced governments to participate in joint efforts on an international basis on how to address a variety of environmental problems of global interest. The establishment of the United Nations Framework Convention on Climate Change (FCCC) and the UN Conference on Environment and Development (UNCED) are among the outcomes of these efforts [1].

The majority of environmental legislators in different countries has accepted that pollution prevention (P2), or waste minimization, is an effective strategy for reducing the environmental impact of industrial processes [2]. To employ this approach, one should assess various methods to reduce the concentration of

environmentally harmful species in process effluents. One method of P2 is called source reduction, which is defined as modifying processing conditions so as to hinder production of pollutants. Although this can be implemented both on retrofit and new design cases, there may be a significant difference between the levels of success in the two cases. This is because there is much more flexibility for implementing any changes before a new design is fixed.

A summary of different P2 methods is given by Lacy [3]. There are different techniques for achieving the goal of each P2 method selected. Clearly, one needs some quantitative measures to determine how effective each P2 technique is.

Based on the above arguments, the general definition of the problem is: "In a retrofit project within an existing process unit, how a practical target can be found to be used for reducing the environmental impact of the process via source reduction?"

## ANALYSIS OF EXISTING APPROACHES

Pollution prevention can be regarded as part of a broader context called 'clean production', or sometimes

\*. Corresponding Author, Department of Chemical Engineering, Sharif University of Technology, Tehran, I.R. Iran.

1. Department of Chemical Engineering, Sharif University of Technology, Tehran, I.R. Iran.

'cleaner production', in the sense that it is aimed at avoiding environmental damage at source.

The WAste Reduction, or WAR, algorithm is one of the methodologies that aim at achieving this goal [4]. In this algorithm, eight potential impact indices are used, namely:

- Ozone depletion potential,
- Global warming potential,
- Acid rain potential,
- Photochemical-oxidation or smog-formation potential,
- Human toxicity potential by ingestion,
- Human toxicity potential by inhalation or dermal exposure,
- Aquatic toxicity potential,
- Terrestrial toxicity potential.

These factors are calculated from process material balance and a relative potential impact score for each chemical present. These indices characterize the generation of potential impact within and the output of potential impact from a process. The indices are used to quantify and to guide pollution reduction with changes to process flowsheets. Alternative process flowsheets are constructed mainly by evolution of the base case, if not intuitively. The scope of the algorithm has recently been expanded to include energy generation and economics. However, it still does not use process optimization and no attempt has been made yet to include a sort of targeting method in the algorithm. Therefore, defining a state space of the process operation is presently not possible in this approach.

A more fundamental problem in WAR algorithm is that no reasonably justified method exists for assigning environmental weighting factors to different chemicals in any objective function. Therefore, the overall impact index of the process is uncertain. This is a still unresolved problem in all methods based on impact indices. Another problem with the algorithm is that all levels of a pollutant are implicitly considered harmful, i.e., although the concentration of a pollutant in a process stream determines the impact indices of that stream, no provisions are made to keep the investigator from calculating indices at even very low concentrations. The method also makes no reference to natural attenuation. However, in some countries, the phenomenon will help in reducing the impact of a pollutant, if its existence can be proved [5].

Nevertheless, one of the definitely important contributions of the WAR algorithm is that by using this approach, in fact a kind of environmental model is included in the problem, although it is not explicitly

expressed. Linking environmental models to process models has been identified as one of the important needs of the modern process design and simulation technology [6].

It is apparent that if a mathematical model of the process under consideration is available, it will be rather easy to assess each design alternative. In a new design, a process model can be studied for any structural or operational modifications that can positively influence the environmental behavior of the design. In a retrofit project, the process can be rated if its simulated model exists. Using the simulated model, the feasibility, efficacy, efficiency, costs, and benefits of any candidate modifications can be examined. Viewing chemical processes in macro-scale, a process simulation model can be combined with an internal or external environmental model. This approach may give a more comprehensive picture of the problem.

Other solutions to the problem come from the field of process synthesis. Closely related and established topics are Mass Exchange Network (MEN) synthesis [7] and Total Site Analysis [8]. MEN synthesis, a combined synthesis and evolutionary design method, is based on "considering thermodynamic feasibility of mass exchange and economic evaluations to synthesize separation networks featuring maximum possible mass exchange while minimizing cost frame" [9].

Although not specifically developed for waste reduction, the MEN synthesis method has been extended to waste reduction studies [9]. In this methodology, first it is assumed that a set of effluent streams (rich streams) and a set of receiving streams (lean streams) exist. In this context, the network is defined as a system of separators and mass transfer units that can achieve, in a cost-effective manner, minimal discharge of hazardous waste streams.

However, if the final effluents of the process are assumed as the rich streams at the beginning of the design, as described in [9], the methodology will be unable later to address structural or operational modifications or improvements in the upstream process that has generated the rich (waste) streams. It has little to say about process modification especially in a retrofit situation. Historically, this is the problem of irreducible structures that was detected in early years of heat exchanger network design research, as well [10]. In this context, it does not help in source reduction. Moreover, it may contribute to cross-media pollution transfer by employing mass separating agents. The latter requires more precise trade-offs to be considered, as discussed elsewhere [11].

Total Site Analysis [8], on the contrary, is designed to be a preventive tool. The basis for calculation in total site analysis is the energy targets obtained in a pinch analysis of all process streams in a plant (site). The main objective of this analysis is predicting

(targeting) overall hot utility and cold utility demands. Additionally, the amount of emissions of furnace  $\text{CO}_2$ ,  $\text{NO}_x$ , and  $\text{SO}_x$  can be determined based on energy use.

However, the idea of targeting prior to design, which is very useful, is not extended to cases where there are process-related emissions. Therefore, emission targeting is possible only if the emissions can be related to energy use [12]. In this approach, no attempt is made in modeling the process or the environment surrounding it. It is true that enhanced separation always need more energy, i.e., the greater the efficiency of separation of pollutants from effluents (cleaner process), the higher the energy consumption. Therefore, one can use the above relationship to establish a trade-off between pollution and energy. However, the trade-off may not be sharp enough and one may not be able to readily recognize the cleanest alternatives in this way.

Life-Cycle Assessment (LCA) is intended for use as a decision support tool in improving environmental performance. It is applied to products and processes. In LCA approach, all activities in production and use of a specific product is considered 'from cradle to grave'. It is believed that in this way, it is possible to determine whether a product or service genuinely causes reduced environmental load, i.e., environmental impacts plus resource depletions, or whether the environmental load is merely transferred from the immediate supplier to other systems [13].

LCA is a useful tool that has been applied to numerous problems so far, and in fact its applicability is increasing. However, certain problems still remain unresolved in this methodology [14]. First, LCA is a highly data-intensive method, and the success of any given study is determined by the availability of good data, which is still a problem in LCA.

Second, serious difficulties arise in 'valuation' step of LCA, i.e., when effect scores from different environmental effects are going to be weighed against each other.

LCA identifies upon which step of the life cycle of a product should more effort be put to improve the overall environmental performance. However, as

a third shortcoming of the technique, LCA does not tell the investigator where the ultimate limit of its performance can be, and, hence, it cannot help in proposing a correction direction.

### Comparison Between Existing Approaches

The general impression here is that all of the above approaches contain some useful tools and ideas that can help in minimizing waste in a complementary manner. A summary of the above methods of approach is provided in Table 1. Therefore, the ideal approach should be a combination of the existing methods. Conceptually, an ideal P2 method should:

- Be based on a process model for examining P2 ideas to be possible,
- Study fate of pollutants in order to fully define their impacts on the environment,
- Be capable of setting targets prior to design, used for making informed decisions,
- Be comprehensive enough to include pollutants not related directly to energy use,
- Be preventive, and not worsening the problem,
- Take practical constraints into account.

The approach proposed here is such a method. In summary, first a mathematical model of the process is constructed. Due to the level of sophistication and calculation power of today's simulation packages, it will be beneficial to use them for this purpose, whenever possible.

The next step is the fate modeling for pollutants. Using the results of this step, the impact of pollutants on the environment can be evaluated more definitively. This requires incorporation of an environmental model in the simulation. Since the model should be flexible enough to be customized for each problem, use of a general-purpose spreadsheet program is recommended.

Finally, with the use of case study tool within the process simulator and the spreadsheet, one should

**Table 1.** Characteristics of various methods in waste minimization.

Method	Models		Advantages	Draw-Backs
	Process	Environment		
WAR algorithm	Simulation	Indices	Simple	Uncertainty No optimization
Mass exchange networks	Profiles	No	Systematic	Not target-setting May not be preventive No impact is included
Total site targeting	Profiles	No	Target-setting Preventive	Limited to energy use
Life-cycle assessment	External	Indices	Established Comprehensive	Not target-setting Data-intensive

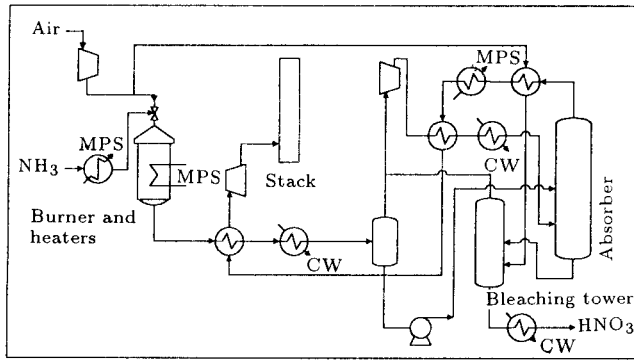

**Figure 1.** Simplified flow diagram of dual-pressure nitric acid production process.

obtain a state space of feasible operational modes of the process based on a precise geometry of the equipment and the environmental conditions as reasonably justified. This is more important in retrofit projects. The information obtained in this step can be used for devising a feasible path.

More details are given in an example application of the method in the next section.

## CASE STUDIES

In this paper, Pollution Reduction Potential (PRP) in an existing 600-ton/day nitric acid production plant near Shiraz, Iran, is first discussed. In an independent study [15], the same process has been used for applying life cycle assessment as a tool for process design. The advantages of the present method will be shown through analyzing that work.

The plant under investigation in this paper utilizes the dual-pressure technology (Figure 1). Modeling of the peculiar chemistry and mass transfer in nitric acid formation is still an active field of study in chemical reaction engineering. Attempts for simulating the process using an artificial neural network is recently reported [16].

### Process Chemistry

In nitric acid production plants of the type under study (dual pressure), ammonia is oxidized on platinum catalyst gauze at about 5 atm, and 880°C to produce nitric oxide, NO. After a number of heat exchange, flashing and compression steps as shown in Figure 1, the gaseous mixture is fed into the bottom of a tray absorption column.

In the absorption column, the mixture of nitrogen oxides comes into contact with water flowing downwards. Several reactions occur in the gas phase, the most significant ones of which, as described in [17] and [18], are reviewed below.

Oxidation of nitric oxide occurs mainly in the gas

phase between the trays of the column:

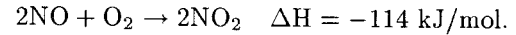

A third-order rate equation is used to describe the kinetics of this reaction:

$$r = \frac{k_p}{RT} p_{\text{NO}}^2 p_{\text{O}_2}.$$

The rate constant is defined by:

$$\log k_p = \frac{652.1}{T} - 1.0366.$$

This reaction is unusual because it goes to the right faster at low temperatures than high temperatures.

The gas phase is also the site of nitrogen dioxide dimerization,



and nitrogen trioxide formation:



Since equilibrium in the nitrogen dioxide dimerization system is established very quickly, an equilibrium formula can be assumed for the rate of this reaction, as follows:

$$r = \frac{k_p}{RT} \left( p_{\text{NO}_2}^2 - \frac{p_{\text{N}_2\text{O}_4}}{K_p} \right),$$

where  $K_p$  is the equilibrium constant. In practice, the dimerization rate is virtually independent of temperature, so the rate constant at 25°C can be used at all temperatures of technical interest.

The equilibrium between  $\text{NO}_2$  and  $\text{N}_2\text{O}_4$  can be described with another equilibrium constant as follows:

$$K_p = \frac{p_{\text{N}_2\text{O}_4}}{p_{\text{NO}_2}^2} = 0.698 \times 10^{-9} \text{Exp} \left( \frac{6866}{T} \right).$$

An equilibrium formula can also be written for nitrogen trioxide formation:

$$r = \frac{k_p}{RT} \left( p_{\text{NO}} p_{\text{NO}_2} - \frac{p_{\text{N}_2\text{O}_3}}{K_p} \right).$$

The equilibrium constant can be determined as:

$$K_p = \frac{p_{\text{N}_2\text{O}_3}}{p_{\text{NO}} p_{\text{NO}_2}} = 65.3 \times 10^{-9} \text{Exp} \left( \frac{4740}{T} \right).$$

Likewise, several reactions take place in the liquid phase, with the ultimate result of nitric acid and nitric oxide production. The main route for the formation of nitric acid involves two steps. First, dissolved nitrogen

tetroxide reacts with water, yielding nitric and nitrous acids:

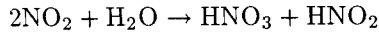

$$\Delta H = -10.72 \text{ kJ/mol.}$$

Nitrous acid dissociates to nitric acid, water, and nitric oxide, the latter being transported across the interface into the bulk gas:

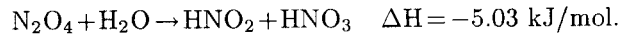

A first-order equation can be written for the rate of nitrogen tetroxide hydrolysis:

$$r = kC_{\text{N}_2\text{O}_4}.$$

The rate constant is given by:

$$\log k = -\frac{4139}{T} + 16.3415.$$

Nitrogen trioxide reacts with water, as well, to form nitrous acid:

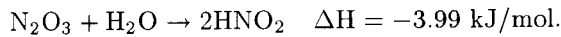

However, nitrous acid is unstable and decomposes instantaneously according to the following reaction:

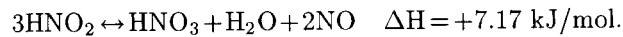

In the present study, the above reaction mechanism along with its corresponding kinetic data are developed into the mathematical model of the absorption process, which is implemented in HYSYS, a commercial chemical process simulator with open architecture and substantial customization and extensibility facilities [19].

The absorption column under study has 31 sieve plates. The tray spacing is not constant along the height of the column and increases every eleven trays. The column is modeled using three separate 'tray sections', each with constant tray spacing.

The two intermediate liquid streams linking the three tray sections have to be regarded as external 'recycle' streams in order to solve the model, although these are actually the internal streams of the column.

Using the mathematical model of the absorption process, the steady state behavior of the process is simulated under different conditions.

### Fate Modeling

Atmospheric dispersion modeling of particulate and gaseous species has been the subject of many investigations [20]. The downwind concentration of the species, i.e., the concentration after dilution, is usually

estimated by reference to the well-known Gaussian plume model [21].

In this model, the ground level concentration of a dispersed component is given as:

$$C_{x,y,z=0} = \frac{Q_m}{\pi\sigma_y\sigma_zU} \exp \left[ -1/2 \left( \frac{y}{\sigma_y} \right)^2 - 1/2 \left( \frac{H_r}{\sigma_z} \right)^2 \right].$$

Maximum ground level concentration can be calculated using the following equation [22]:

$$C_{\max} = \frac{2Q_m}{e\pi H_r^2 U} \left( \frac{\sigma_z^*}{\sigma_y} \right).$$

Holland empirical equation that gives the value of plume rise was used for obtaining effective height of stack based on buoyancy and momentum effects in the stack gas [22], which is written as:

$$\Delta H_r = \frac{U_s d}{U} \left[ 1.5 + 2.68 \times 10^{-3} Pd \frac{T_s - T_a}{T_s} \right].$$

In the present study, the dispersion calculations are based on Pasquill-Gifford continuous three-dimensional deterministic plume model (Figures 2 and 3). The parameters of the model are given in the literature [21,22] according to the stability class of the atmosphere as summarized in Table 2. The historical meteorological data required for tuning the model were obtained from the records of a measuring station nearest to the site.

The dispersion model was fed with the data obtained in the process simulation step and was used for fate modeling of the emitted harmful species ( $\text{NO}_x$ ). Experimental maximum and average ground level concentration of  $\text{NO}_x$  were used to check the validity of the calculated concentrations within accuracy margin of the dispersion model [23]. Figure 4 demonstrates the comparison between the experimental data, shown with dots, and the expected confidence level of the dispersion model [23].

### Sensitivity Analysis

The main objective here is to quantify the environmental impact of the efflux nitrogen oxides. To optimize the process based on this criterion, the process model was linked to the atmospheric dispersion model. The latter was implemented in a spreadsheet.

Linking the two models, it was possible to examine the ultimate ground level concentration of harmful species based on three kinds of parameters, namely their exit concentrations, the geometry of the stack, and the operating conditions of the plant. Sensitivity analysis was conducted within the spreadsheet which also made graphical representation of improvement trends and environmental as well as health analyses. The results of the sensitivity analysis are summarized

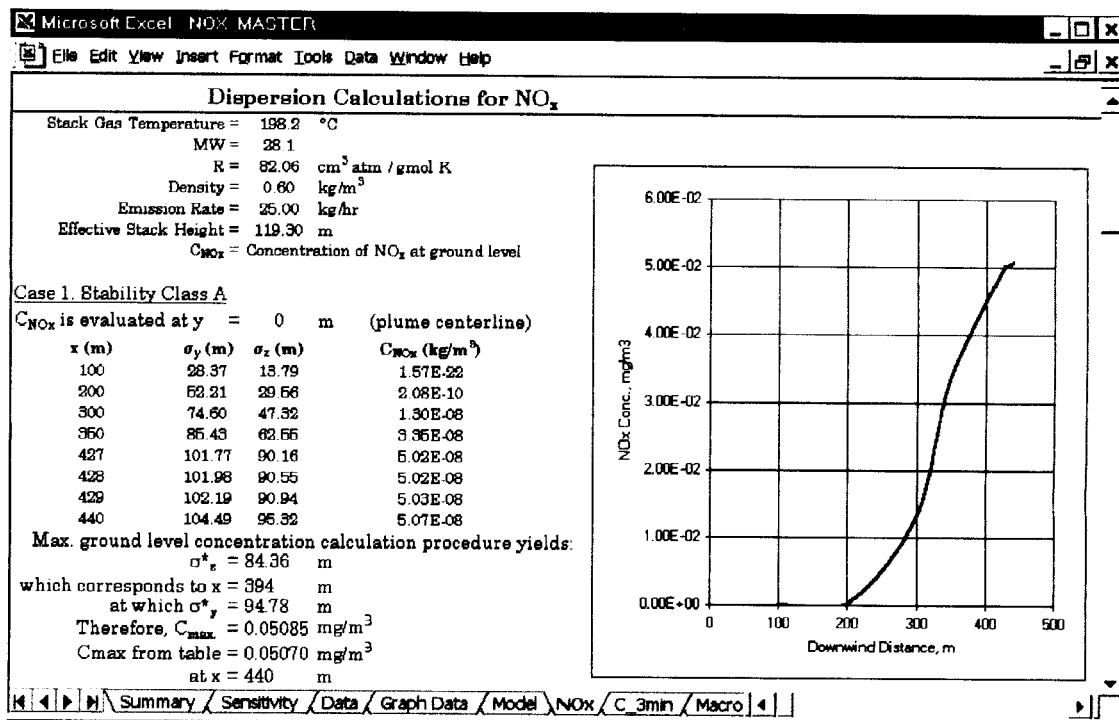

Figure 2. The environmental model as applied in the study.

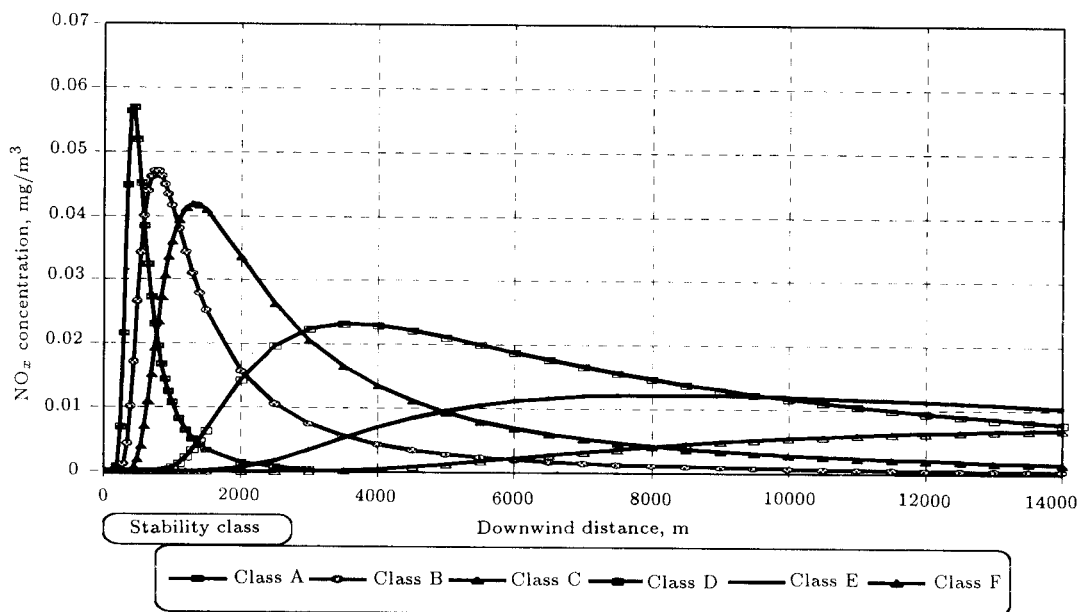

Figure 3. The atmospheric dispersion behavior of the pollutant (NO<sub>x</sub>).

in Table 3. The last row of the table shows the extent of change in the three categories of parameters necessary to achieve a certain level of reduction in maximum ground level concentration of NO<sub>x</sub>. Comments on the results and conclusions are as follows.

As stated earlier in this paper, nitric acid production process formed the basis for an independent study [15] in which LCA was used to quantify and

compare environmental performance of two design alternatives aimed at waste reduction.

The two alternatives were: (1) Addition of a Selective Catalytic Reduction (SCR) unit downstream of the absorption section, an end-of-pipe type solution, and (2) Raising the absorption pressure from 3.5 barg to 7.5 barg, thereby reducing pollutant source.

In that work, the authors incorporated an eco-

**Table 2.** The atmospheric dispersion coefficients [22].

Stability Class	Downwind Distance 'x' (m)	Directional Dispersion Coefficients (m)	
		$\sigma_y$	$\sigma_z$
A	-	$0.493x^{0.88}$	
	100-300		$0.087x^{1.10}$
	300-3000		$10^{[-1.67+0.902 \log(x)+0.181(\log(x))^2]}$
B	-	$0.337x^{0.88}$	
	100-500		$0.135x^{0.95}$
	500-20000		$10^{[-1.25+1.09 \log(x)+0.0018(\log(x))^2]}$
C	-	$0.195x^{0.90}$	
	100-100000		$0.112x^{0.91}$
D	-	$0.128x^{0.90}$	
	100-500		$0.093x^{0.85}$
	500-100000		$10^{[-1.22+1.08 \log(x)-0.061(\log(x))^2]}$
E	-	$0.091x^{0.91}$	
	100-500		$0.082x^{0.82}$
	500-100000		$10^{[-1.19+1.04 \log(x)-0.070(\log(x))^2]}$
F	-	$0.067x^{0.90}$	
	100-500		$0.057x^{0.80}$
	500-100000		$10^{[-1.91+1.37 \log(x)-0.119(\log(x))^2]}$

**Table 3.** Ground level concentration of  $\text{NO}_x$  vs. plant parameters.

Max. $\text{C}_{\text{NO}_x}$ ( $\text{mg}/\text{m}^3$ )	Exit Temp. ( $^\circ\text{C}$ )	Exit Pres. ( $\text{kg}/\text{cm}^2$ )	$\text{NO}_x$ Flow-Rate ( $\text{kg}/\text{hr}$ )	Stack Height (m)
0.0569	158	0.875	25.0	57
0.0551	169	0.836	24.5	60
0.0507	198	0.748	22.2	65
% Change (Abs.)	25.4	14.5	11.2	14.0

nomic model into their life cycle assessment and optimized the solution with both economic and environmental objectives. As a result, they concluded that source reduction was superior to installing the SCR unit.

Finally, they gave a summary of various areas of

their work that were not perfect and needed improvement, including the following items:

1. Since LCA is a very data-intensive procedure, a special software with a built-in capability of defining processing blocks was used to facilitate the study;

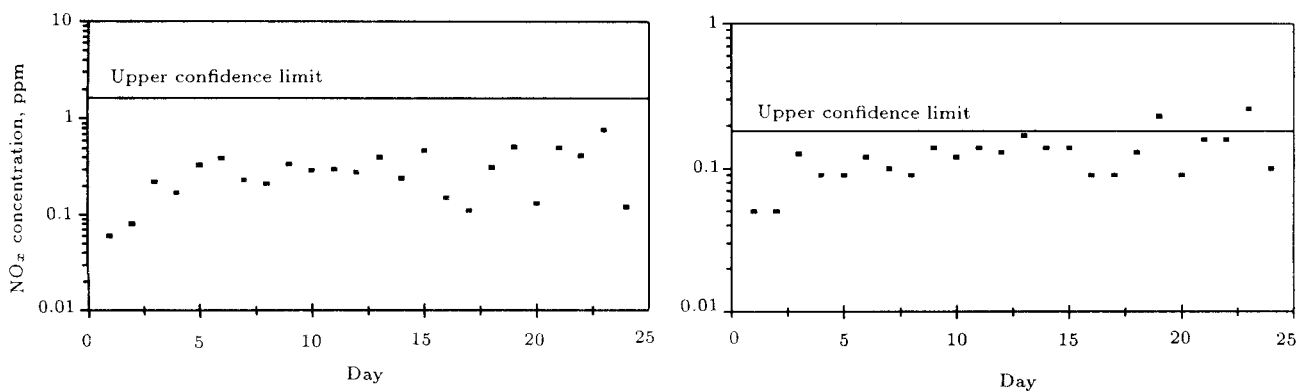

**Figure 4.** Modeled pollution ( $\text{NO}_x$ ) concentration checked against measured data; Left: max. 1-hr conc., Right: av. 1-hr conc.

2. Ranking of environmental impacts was based on the magnitude of their responses to changes in process variables, rather than their sociological effects.

Furthermore, there are additional shortcomings in that approach, not explicitly stated by the authors, as follows:

1. For calculating the environmental impact of  $\text{NO}_x$ , its rate of discharge, i.e., the value obtained from material balance, was used. Obviously, the impact on the environment can be more reliably evaluated if  $\text{NO}_x$  concentration on the ground is used instead of  $\text{NO}_x$  rate at the top of the stack;
2. The reaction chemistry is very simplistic, as adopted and stated by the authors, in the sense that they use only NO and  $\text{NO}_2$  in their process model, although in practice various  $\text{NO}_x$  species are present. The over-simplicity of the model may lead to large errors in a complex system like nitric acid production;
3. The effect of raising the absorption pressure in the second alternative was taken for granted based on data from the literature. No attempts were made to evaluate it on the simulated process model;
4. Pollution was assumed to be due to emission of  $\text{NO}_x$ , i.e., a combination of NO and  $\text{NO}_2$ . In reality, the environmental impact of the two species is not identical, because of their different physical properties;
5. The selected alternative (raising  $P$ ) requires nearly doubling the operating pressure in the absorption section. Obviously, new equipment with the corresponding higher design pressure is needed for this purpose. Although the corresponding capital cost is already incorporated into optimization, implementation of this alternative by plant management is questionable, due to its relatively higher initial investment and probably low rate of return on investment.

## RESULTS AND DISCUSSION

Results of a sensitivity analysis on the model presented here are summarized in Table 3. In this table, it is demonstrated that:

- For a certain amount of  $C_{\max}$  reduction, only 11.2% change in the amount of nitrogen oxides in the stack gas is necessary, compared to 14-25.4% for other variables. Therefore, no parameter is as effective in minimizing the ground level concentration of  $\text{NO}_x$  as the amount of the oxides in the stack gas, as was expected. This is in strict accordance with that experienced by other investigators that have generally recommended source reduction as the most viable alternative in these studies;

- As the amount of nitrogen oxides in the stack gas is a function of the operating temperature and pressure of the absorption tower, these variables can be manipulated to find the optimal operating mode of the tower. It is noteworthy that in this way the amount of product (nitric acid) produced is also affected in a favorable way. That is, the less  $\text{NO}_x$  is discharged from the top of the tower, the more acid is produced;
- Since nitric oxide (NO) is a pollutant as well as a reactant (feed), its absorption efficiency and the process yield vary in the same direction. That is, the amount of product (nitric acid) produced is also affected in a favorable way when less NO is discharged from the top of the tower. Therefore, one cannot trade-off pollution prevention quantity - the amount of nitric oxide discharged - with the quantity of acid produced. In other words, it is possible to have the benefit of the amount of pollution that is avoided (not discharged to atmosphere through good operation) and the extra amount of useful product (nitric acid) produced in this way, simultaneously. Of course, the increased efficiency of separation requires additional investment and/or it increases operating costs. For example, the operator can install tower packings, even a second absorption tower, or increase water circulation rate. Therefore, the first trade-off is between reduced pollution plus higher production rate (favorable), and increased operating costs (non-favorable);
- If the first trade-off cannot be used for improving the environmental behavior of the plant, at least the concentration of nitrogen dioxide ( $\text{NO}_2$ ) in stack gas can be reduced at the expense of more nitric oxide remaining un-reacted and less  $\text{HNO}_3$  produced. Since Nitrogen dioxide is widely considered more hazardous than nitric oxide (NO), a second trade-off exists between reduced impact and reduced benefits (less useful product);
- The two trade-offs can be used to obtain practical targets for pollution prevention as a retrofit tool. It is accomplished by the identification of the most promising alternatives for reduction of  $\text{NO}_x$  emissions. The alternatives are based on changing the operating temperature and/or pressure of the  $\text{NO}_x$  absorber, which has been reported by industry sources [24], and here only those results have been quantified.

To summarize the general characteristics and results of this study, it can be stated that:

1. More rigor has been incorporated into the 'process model' part compared to other investigators;



2. Real plant data were used for modeling contrary to a number of other papers. This improves the confidence on the results of the analysis;
3. The simulated process model, although rigorous, is still simple enough for practical implementation;
4. The combined model is maintainable; new calculations can be incorporated very easily;
5. With changes in the interface, it can be used with any other simulation model as long as the streams that contain the pollutants under study are known. Only minor development efforts are required.

## CONCLUSIONS

A combination of a rigorous chemical process model with an environmental description of the fate of the pollutants was used for sensitivity analysis of environmental impacts of pollutants. In this way, the optimal state space of plant operations has been identified to minimize impacts within the context of regulatory limitations. The details of the approach are shown through applying it to an industrial plant.

Comparison between the proposed methodology and an independent older study reveals the advantages of the proposed approach, as follows:

1. Using an environmental fate model, as in this work, the concentration of the pollutants can be tracked. This is more appropriate for impact analysis compared to pollutants flow-rates, as used by other investigators;
2. Through modeling and simulation of the chemical process under consideration, as in this work, the effect of changes in operating variables can be studied thoroughly. In similar studies, mainly literature data are used for this purpose as discussed above.
3. The environmental impacts of different chemical species can be dealt with separately. In this paper, it was shown that this may reveal hidden trade-offs, as illustrated with NO and NO<sub>2</sub>.
4. It was shown that when there is only a limited number of alternatives, the analyst may choose an alternative that may have practically a very low return on investment. One of the advantages of the present work, therefore, is that using process simulation technology, a continuous space of alternatives can be obtained for further evaluation in the light of practical constraints, or these constraints can be incorporated directly into the optimization.

## ACKNOWLEDGMENT

Authors wish to sincerely thank the R & D Department of National Petrochemical Co. (NPC) and Shiraz Petrochemical Co. for supporting this study.

## NOMENCLATURE

$C$	concentration in liquid phase, kmol m <sup>-3</sup>
$C_{\max}$	maximum concentration of a pollutant on the ground, mg m <sup>-3</sup>
$C_{x,y,z=0}$	ground level concentration of the pollutant, mg m <sup>-3</sup>
$d$	stack inner diameter, m
$\Delta H_r$	plume rise, m
$H_r$	effective stack height, m
$k$	rate constant, atm <sup>-2</sup> s <sup>-1</sup>
$k_p$	reaction rate constant, atm <sup>-2</sup> s <sup>-1</sup>
$K_p$	equilibrium constant, atm <sup>-1</sup>
$p$	partial pressure, atm
$P$	atmospheric pressure, mbar
$Q_m$	release rate of a pollutant, kg h <sup>-1</sup>
$r$	reaction rate, kmol m <sup>-3</sup> s <sup>-1</sup>
$R$	universal gas constant, m <sup>3</sup> atm kmol <sup>-1</sup> K <sup>-1</sup>
$T$	temperature, K
$T_a$	ambient air temperature, K
$T_s$	stack gas exit temperature, K
$U$	wind speed, m s <sup>-1</sup>
$U_s$	stack gas exit velocity, m s <sup>-1</sup>
$y$	distance crosswind, m
$z$	vertical distance, m
$\sigma_y$	dispersion coefficient in crosswind direction, m
$\sigma_z$	dispersion coefficient in vertical direction, m
$\sigma_z^*$	$H_r/\sqrt{2}$

## REFERENCES

1. Kirkwood, R.C. "Environment and human influence", in *Clean Technology and the Environment*, R.C. Kirkwood and A.J. Longley, Eds., Blackie Academic & Professional (1995).
2. Shanley, S. "Pollution prevention: Reinventing compliance", *Chem. Eng.*, pp 30-43 (Nov., 1993).
3. Lacy, W.J. "Pollution prevention and waste minimization", in *Riegel's Handbook of Industrial Processes*, J.A. Kent, Ed. Chapman & Hall (1997).
4. Cabezas, H. et al. "Pollution prevention with chemical process simulators: The generalized waste reduction (WAR) algorithm - Full version", *Computer. & Chem. Eng.*, **23**(4-5), pp 623-634 (1999).
5. Swett, G.H. and Rapaport, D. "Natural attenuation: Is the fit right?", *Chem. Eng. Prog.*, pp 37-43 (June, 1998).

6. Hilaly, A.K. and Sikdar, S.K. "Process simulation tools for pollution prevention", *Chem. Eng.*, pp 98-105 (Feb., 1996).
7. El-Halwagi, M.M. and Manousiouthakis, V. "Synthesis of mass exchange networks", *AIChE J.*, **35**(8), pp 1233-1244 (Aug., 1989).
8. Dhole, V.R. and Linnhoff, B. "Total site targets for fuel, co-generation, emissions and cooling", *Computer & Chem. Eng.*, **17**, Suppl., s101-s109 (1993).
9. Papalexandri, K.P. et al. "Mass exchange networks for waste minimization: A simultaneous approach", *Trans IChemE Chem. Eng. Res. Des.*, **72**, Part A, pp 279-294 (May, 1994).
10. Smith, R., *Chemical Process Design*, pp 8-13, McGraw-Hill (1995).
11. Pearce, D.W. "The economics of pollution", in *Clean Technology and the Environment*, R.C. Kirkwood and A.J. Longley, Eds., Blackie Academic & Professional (1995).
12. Linnhoff, B. "Pinch analysis - A state-of-the-art overview", *Trans. IChemE Chem. Eng. Res. Des.*, **71A**, pp 503-522 (Sept., 1993)
13. Clift, R. and Longley, A.J. "Introduction to clean technology", in *Clean Technology and the Environment*, R.C. Kirkwood and A.J. Longley, Eds., Blackie Academic & Professional (1995).
14. Weidema, B.P. "LCA developments for promoting sustainability", *Keynote Lecture Presented at 2nd National Conf. On LCA*, Melbourne (2000).
15. Kniel, G.E. et al. "Life cycle assessment applied to process design: Environmental and economic analysis and optimization of a nitric acid plant", *Env. Prog.*, **15**(4), pp 221-228 (1996).
16. Roj, E. and Wilk, M. "Simulation of an absorption column performance using feed-forward neural networks in nitric acid production", *Computer & Chem. Eng.*, **22**, Suppl., s909-s912 (1998).
17. Suchak, N.J. et al. "Modeling and simulation of NO<sub>x</sub> absorption in pilot-scale absorption columns", *AIChE J.*, **37**, p 323 (1991).
18. "Nitric acid, nitrous acid, and nitrogen oxides", in *Ullmann's Encyclopedia of Industrial Chemistry*, Fifth Ed., **A17**, pp 293-339, Wiley-VCH Verlag, GmbH (1991).
19. "HYSYS. Process customization guide", Hyprotech Ltd., Calgary, Canada (1998).
20. Hanna, S.R. et al. "Evaluation of fourteen hazardous gas models with ammonia and hydrogen fluoride field data", *J. Haz. Mat.*, **26**, pp 127-158 (1991).
21. Lees<sup>†</sup>, F.P., *Loss Prevention in the Process Industries*, Butterworth-Heinemann, 2nd Ed., Chapter 11 (1996).
22. Crowl, D.A. and Louvar, J.F., *Chemical Process Safety: Fundamentals with Applications*, p 139, Prentice-Hall (1990).
23. Beychok, M.R., *Fundamentals of Stack Gas Dispersion*, published by the author, Irvine, California, USA (1994).
24. Anon. "Absorber design in nitric acid plants", *PROCESS TECHNOLOGY, Nitrogen*, **188**, pp 21-28 (Nov.-Dec., 1990).